

# Light Hammer® 6

## High Power 6-Inch UV Curing System

Ultraviolet (UV) curing is a photochemical process in which high intensity UV is used to instantly cure inks, coatings or adhesives in a wide range of industries. Offering many advantages over traditional drying methods, UV curing has been shown to increase production speed, reduce reject rates, improve scratch and solvent resistance, and facilitate superior bonding. The Light Hammer® 6 brings all of the benefits of microwave-powered UV curing to a six-inch (150 mm) system.

Operating in the power class of 500 watts/inch (200 watts/cm), the Light Hammer® 6 features two easy-to-service modular components: the microwave-powered irradiator and the solid-state power supply. At the heart of the microwave technology is the electrodeless bulb mounted in an elliptical reflector for focusing an intense strip of UV energy 53 mm (2.1 inches) below the face of the lamp.

### Electrodeless Technology

The microwave-powered lamp and its electrodeless bulb technology have proven

themselves over time and in hundreds of demanding applications. These long life bulbs are known for their stable performance, high intensity and low maintenance operation.

### Popular Bulb Spectra Available

The standard bulb spectra are available: “H” spectral distribution is suited for clear-coats and varnishes; the “D” spectral distribution is popular and proven for inks and thick coatings or adhesives; and the “V” distribution is effective for UV curing white basecoats, through laminating materials and in other specialty applications.



## Fast UV Curing from High Peak Irradiance and Low Infrared

The small diameter bulb combined with the elliptical reflector provides high peak of UV irradiance for high-speed cure. The small diameter bulb also reduces infrared emission resulting in lower surface temperatures of the substrate, thus eliminating the need for complicated heat removal methods.



## Higher Efficiency from the Solid-State Power Supply

Each lamp system has its own microprocessor-based, modular power supply. The high voltage circuit inside the power supply consists of a solid-state, switching engine. This reduces ownership costs because it extends the life of the magnetron and the bulb by supplying a constant source of power to the lamp.

(Process patent US 6908586B2.)

The solid-state electronics run cooler and more efficiently – saving money on power, reducing environmental noise and space requirements.

Power output from 25% to 100% can easily be controlled from the front panel or remotely through contact closure from a PLC (programmable logic controller). This variable power feature permits matching of the lamp output to the machine/line speed or to the ink/coating demands.



A sophisticated microprocessor control system allows multiple lamp systems to be interconnected and controlled individually or as a group. And there is no loss of illumination at the juncture of two lamps so that multiple irradiators can be joined end-to-end or in a continuous array for large processes.

## “Electronic Shutter”

Integration of the lamp into processes, which require a rapid on/off cycle, is now realized without the use of a bulky, mechanical shutter. The Light Hammer® 6 can repeatedly cycle from high power to very low power over a few seconds. Shutters are not required, owing to the fast response of the lamp to control demand. This cycling operates under reduced air-cooling as a function of duty cycle (*see figure below*).

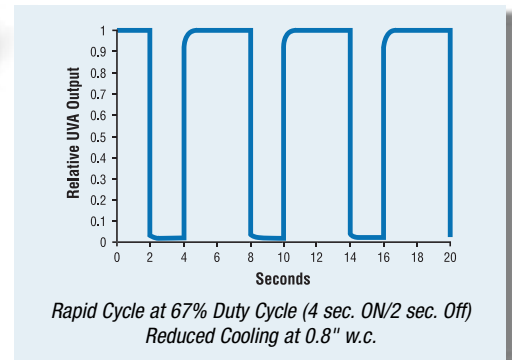

## Improved Cure

The ultimate benefit of the Light Hammer® 6 is the achievement of higher degrees of conversion than is typically achieved with high ripple (AC) powered UV sources. (Process patent US 6908586B2.)

# Specifications: Light Hammer® 6

## Irradiator Models

**High Pressure Version** – for full power operation.

- I6P1 with top air inlet; requires remote blower.
- I6P3 with side air inlet; 387 mm tall (15.2 in.), requires remote blower.
- I6B with a fixed-air integral blower.
- I6S with side air inlet, requires remote blower.

**Low Pressure Version** – for reduced power operation and rapid power cycling (ie. electronic shutter).

- I6P1LH with top air inlet; requires remote blower.
- I6P3LH with side air inlet; 387 mm tall (15.2 in.), requires remote blower.
- I6SLH with side air inlet; 375 mm tall (14.75 in.), requires remote blower, switch measures pressure differential of lamp.
- I6S/ULC with side air inlet; 375 mm tall (14.75 in.).

**Lamp Power:** Full power: 200 watts/cm (500 watts/inch).

**Bulb Type:** Standard style BF9. Standard spectra available.

**Irradiator Dimensions:** See figures below, dimensions in mm. Allow space for inlet collar, air connection and electrical connection.

**Footprint:** 168 mm (6.6 in.) x 168 mm (6.6 in.).

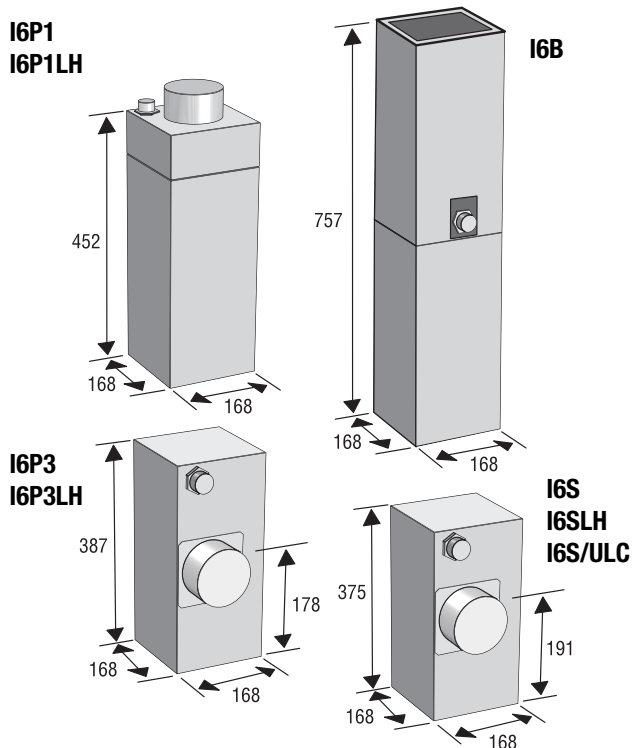

**Weight:**

- I6P1, I6P1LH: 9.7 kg (21.4 lbs.).
- I6P3, I6P3LH: 9.1 kg (20.0 lbs.).
- I6S, I6SLH, I6S/ULC: 10.8 kg (23.9 lbs.).
- I6B: 13.1 kg (28.8 lbs.).

**Reflector Geometry:** Semi-elliptical, maximum irradiance 53 mm (2.1 in.) from face of lamp.

**Mounting Position:** May be mounted and operated in any position.

**Minimum Cooling at 100% Power:** 4.8 m<sup>3</sup>/min at 1.24 kPa (170 cfm @ 5.0 in. w.c.).

**Exhaust:** Recommend 130% of the required volume of cooling air be exhausted.

## Power Supply:

**Dimensions:** 420 mm (16.5 in.) wide x 223 mm (8.8 in.) high x 648 mm (25.5 in.) deep.

**Rear Clearance:** Recommended minimum 300 mm (12 in.).

**Weight:**

- LH6: 22.9 kg (50.5 lbs.).
- LH6B: 26.7 kg (58.9 lbs.).

**3-Phase Voltage:** 200-240/380-415/440-480 V (50/60 Hz).

**Maximum Line Power:** 6.8 kVA at 100% power (LH6).

**Maximum Line Current:** 18 Amps/phase maximum for Low Voltage units (200-240 VAC); 9 Amps/phase maximum for High Voltage units (380-480 VAC) (LH6).

**Cooling:** Internal air-cooled fan.

**Control Voltage:** Supplied internally.

## Power Supply Controls/Displays

**Front Panel Controls:**

- Lamp On, Standby, Lamp Off/Reset, Power Level Control.

**Display:**

- Operating power level.
- LED ON indicates Master (Off=Slave) for Multiple Lamp Systems.
- LED indicates Unit faults: Lamp, Inverter Faults, Magnetron Faults, Over Temperature, Blower Pressure, Cable Disconnects.
- LED indicates System faults: System Blower, External Interlock, RF Interlocks.

**Magnetron Power Levels:**

- **Variable Power:** 25% to 100% in 1% steps with front panel dial control.
- Digital or Analog set using switches on internal I/O board.
- Quick Restart Mode (QRM or “electronic shutter”) from low to high power for use in rapid on/off cycling mode.

**Remote Inputs & Outputs:**

- **Interlocks:** RF-1, External, System Blower, Cable Disconnect, Blower Pressure, Over Temperature, Magnetron Fault, Inverter Fault, Lamp Out.
- **Remote Inputs:** Off, Standby, On, Digital or Analog Power Control.
- **Outputs:** (K1) Filament On; (K2) HV ON; (K3) Lamp On; (K4) Press Enable; (K5) Standby Ready; (K6) Photocell.

## System Specifications:

**Ambient Operating Temperature:** 0-50 degrees Celsius for I6 series, 0-45 degrees Celsius for I6B, 0-35 degrees Celsius for I6S/ULC.

**Relative Humidity:** 30-95% (non-condensing).

**Compliance:** TUV; MIL-STD-810F, figure 514.5C-17; CE.

**Connections:** 4 m (13 ft.) cable from power supply to irradiator (other cable lengths available). Line power connections and fuses disconnect to be supplied by user.

## Optional System Accessories Available:

**Adapter Rails:** A pair of bars which can be attached to the sides of the I6 lamp housing to provide the same footprint as Model I300M. These external rails also provide mounting surfaces for attachments, such as model F6 or C6 secondary reflector housings.

**Cross-wise Adapter Plate:** Allows I6 irradiator to be mounted in a light shield for I300M; positions irradiator in a 90-degree orientation to the I300M position.

**External End Reflectors:** Flat plate UV reflectors, constructed of light gauge aluminum with R500 UV reflective surface; designed to fit in a light shield to provide increased radiant uniformity over full length of bulb.

**(Remote) Pressure Blower:** Vane-type blower with air intake filter housing, to provide filtered air to the irradiator with the proper flow and pressure. A number of power options and configurations are available.

**Conveyors:** Belt and roller conveyors, web, cable and fiber systems are available. Other special product handling systems can be quoted on request.

**Note:** Specifications are for a single lamp system whose length is 168 mm (6.6 in.). Adding irradiators and power supplies can make a larger system. Irradiator modules placed end-to-end effectively form a continuous lamp of any length, which are multiples of 168 mm (6.6 in.). Some specifications will increase proportionally with the number of lamps in a system.

The Light Hammer® 6 is the result of Fusion UV Systems, Inc.'s continued commitment to develop improved ultraviolet curing systems that meet our customers' demands for higher production speeds, better process control, enhanced reliability and ease of use for demanding production requirements.



## FUSION UV SYSTEMS, INC.®

### **Fusion UV Systems, Inc. Corporate Headquarters**

910 Clopper Road  
Gaithersburg, Maryland  
20878-1357 USA  
+1 301-527-2660  
FAX: +1 301-527-2661  
+1 888-276-8600  
(North American Toll Free)  
www.fusionuv.com  
e-mail: info@fusionuv.com

### **Fusion UV Systems West**

Torrance, California  
+1 310-370-9920  
FAX: +1 310-370-9152

### **Fusion UV Systems GmbH**

Ismaning, Germany  
+49 89 899631-0  
FAX: +49 89 899631-10  
www.fusionuv.de

### **Fusion UV Systems Spectris China Ltd.**

www.fusionuv.com.cn  
Beijing, China  
+8610-59935827/28  
FAX: +8610-59935999  
Guangzhou, China  
+86 20 8756 8900  
FAX: +86 20 2887 3848  
Shanghai, China  
+86 21 61133698  
FAX: +86 21 61133699

### **Fusion UV Systems Japan KK**

Tokyo, Japan  
+81 3 5542 3980  
FAX: +81 3 5542 3992  
www.fusionuv.co.jp

ISO 9001 Certified QMS



• U.S. Patent No. 3911318; 3872349; 3983039; 4042850; 4208587; 4359668; 4313969; 4269581; 4485332; 4507587; 4868509; 5471109; 5726815; 6419743; 6419749; 6509656; 6626561; 6646384B2; 6690112B2; 6740892B2; 6908586B2; 7037460B2; 7055990B2 • U.K. Patent No. 1482950 • Japan Patent No. 1142145; 1130584; 1974504; 2704982 • France Patent No. 7428765  
• Canada Patent No. 1024246 • Other U.S. and Foreign Patents Pending.  
We reserve the right to incorporate changes and improvements without notice.

06/09 Printed in USA SB 647 ©2009 Fusion UV Systems, Inc. The logo symbol, Fusion UV Systems, Inc., and Light Hammer are registered trademarks of Fusion UV Systems, Inc.